

## Key Instructions for Timber Fence Post erection

### **NEW POST INSTALLATION:**

#### **Fixing the Posts:**

- 1) The size of the hole is dependent on the height and type of the fence.
- 2) It is recommended that all timber posts to be fixed in the ground using concrete to give stability once set. However, note that the posts will inevitably shrink and swell with changes in weather.
- 3) It is important to note that the Timber Posts must be set in concrete on top of a minimum of 2 inch Ballast/Gravel as shown in Figure 1. This will allow drainage to take place between the post and the concrete. If the post is merely set

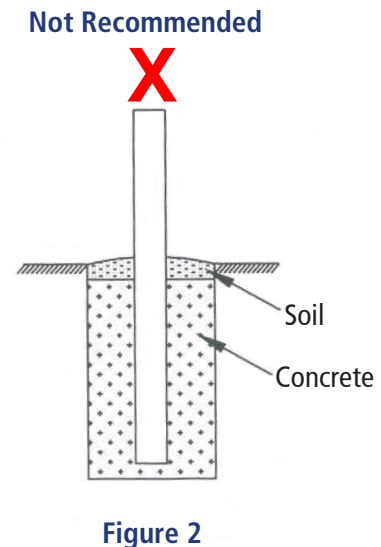
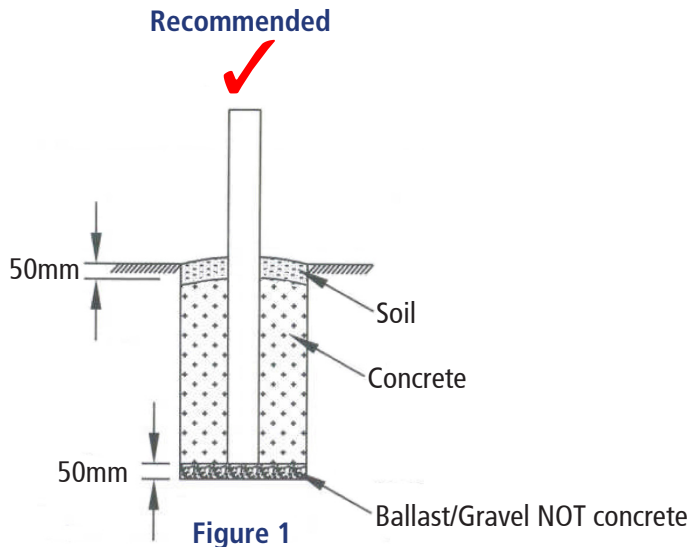

in the concrete base as shown in Figure 2, then drainage cannot take place and could lead to premature rotting under certain conditions. The Ballast/Gravel also makes final positioning easier, before adding the concrete.

- 4) Backfill the holes at the top with soil to make a mound and slope it away from the post to keep water from collecting around it, this will also settle in time.

### **REPLACEMENT OF AN EXISTING POST:**

- 1) When replacing an existing post which is rotten / damaged, it is necessary to excavate soil around the post as shown in Figure 3a & Figure 3b below.

#### **a) If post to be replaced was installed in soil only.**

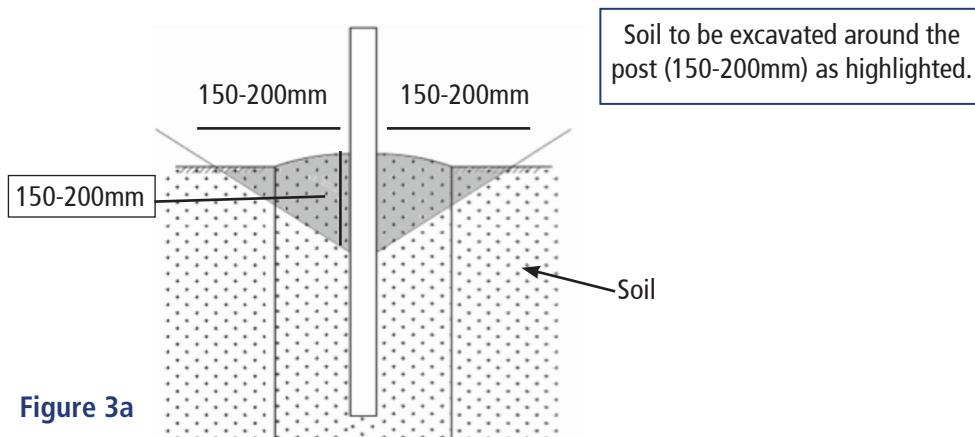

**b) If post to be replaced was installed in concrete.**

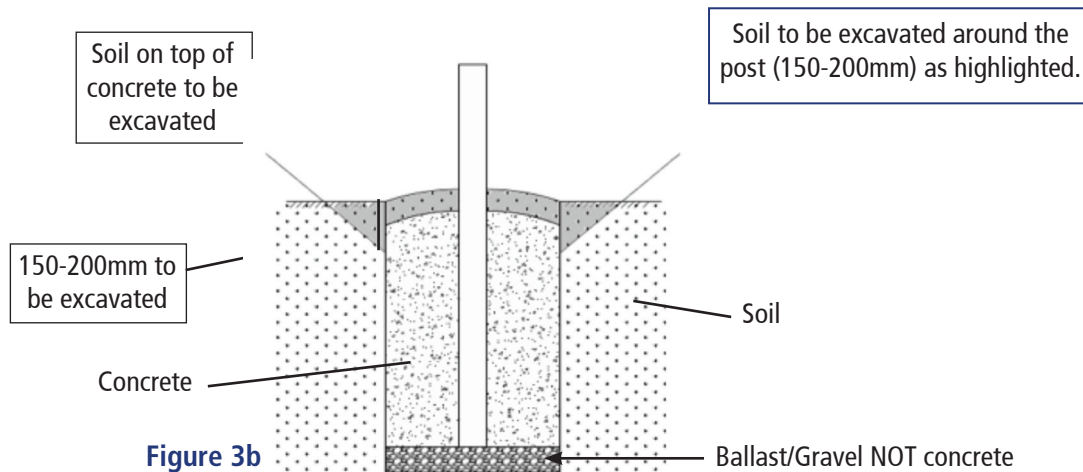

**Safety Notes:**

Please ensure that your work area is clear and tidy and that components and tools are close to hand. When using hand and power tools please ensure that you follow the manufacturer's safety instructions including the use of safety glasses and gloves. When using ladders or lifting heavy objects please observe correct procedures. Only lift objects that are well within your capability. Avoid overhead lines.

Consider whether underground services (electricity cables, gas pipes, water, etc) exist in an area to be excavated. Use a Cable Avoidance Tool (CAT scanner) wherever possible. Watch out for signs of services (coloured gravel etc.) as excavation continues. Do not use a mechanical excavator within 500mm of detected services.



**SAFETY BOOTS AND HI VIZ CLOTHING MUST BE WORN AT ALL TIMES, USE GLOVES WHEN HANDLING CONCRETE**

**Additional Safety Notes:**

Biocidal Products Regulation (EU528/2012):

Jakcured articles incorporate biocidal products to protect against wood destroying organisms.

Active ingredients include: Copper(II)Carbonate / Copper(II)Hydroxide / Propiconazole / Tebuconazole

Wear gloves when handling freshly treated wood. Avoid breathing dust when cutting. Dispose of off-cuts responsibly – do not burn.

Jacksons Fencing Head Office Stowting Common Ashford Kent TN25 6BN  
Tel +44 (0) 1233 750393 Fax +44 (0) 1233 750403  
www.jacksons-fencing.co.uk info@jacksons-fencing.co.uk

**Jacksons  
Fencing**